

# General Information About the Liberal Studies Math Proficiency Assessment

The Liberal Studies Mathematics Proficiency Assessment is a 36 item multiple-choice test, composed of two sections with 18 items each. A score of **11 or better** on each section of the Liberal Studies Mathematics Proficiency Assessment currently allows one to enroll in MATH 311, MATH 313 or MATH 315.

Calculators are NOT allowed. Sign up in the Test Office (SS 2549; 619-594-5216). The examination is usually given once a month, including the first Saturday of classes each semester. There are sign-up deadlines and a fee for the examination.

The first section of the exam requires an understanding of fundamental concepts of **numbers and operations** including the following:

- a. Meanings of whole numbers and fractions (including mixed number, decimal, ratio, and percent forms);
- b. Meanings of operations (addition, subtraction, etc.) with those numbers; standard and alternate algorithms;
- c. Numeration, including scientific notation and non-decimal bases;
- d. Number sense: size, estimation, mental arithmetic; and
- e. Analysis and solution of word problems through reasoning about quantities and their relationships, including proportional situations.

The second section of the exam requires an understanding of fundamental concepts of **geometry and measurement** including the following:

- a. Terminology and representations of two- and three-dimensional shapes; relationships in such shapes;
- b. Quantities associated with shapes (length, area, volume, angle size);
- c. Geometric relationships like the angle sum for a triangle, similarity, and the Pythagorean theorem;
- d. Key ideas of measurement; and
- e. Derivation and application of measurement formulas, metric and systems of units.

You will likely find it helpful to review your notes and your textbook(s) for your versions of MATH 210 and MATH 211. There is a copy of one standard textbook (Musser & Burger, *Mathematics for Elementary Teachers*) in the Reserve Room of Love Library.

## Multiple Choice Review Items for the Liberal Studies Math Proficiency Assessment

Although these review items are not organized as though they were on a test, you should work on them as though they were on a test, working fast but carefully. You should be able to do all of these without a calculator; any necessary calculations are kept simple. When extensive calculation seems necessary, look again. It is likely that the use of number sense can make the item do-able mentally or with easy paper-pencil calculation. To spend time on extensive hand calculation cuts into the time available for other items.

The Mathematics Placement Test, Part LS, consists solely of multiple-choice items so that it can be machine scored, but a few items here are open response since those are regarded as a better review of the ideas. In all cases, you should ask yourself, "What is this item testing?"

Note: These questions were prepared independently of the Test Office, and hence are NOT, in all probability, sample questions that appear on the different forms of the Placement Examination.

### Review Items for Part 1 of the Assessment (Numbers and Operations)

1.  $0.7614987 \times 159.23842$  is about...  
A. 1.2    B. 12    C. 120    D. 1200    E. None of A-D
2.  $1.334496 \times 301.66$  is closest to...  
A. 400    B. 390    C. 390    D. 40    E. 39
3.  $278.4132987 \times 0.2617944285$  is about...  
A. 7    B. 70    C. 700    D. 7000    E. None of A-D
4. Of the estimates listed, which is best for  $0.3247876 \times 629.347291143$ ?  
A. 1800    B. 180    C. 200    D. 210    E. 240

5. As a decimal, 0.525% is...
- A. 525    B. 52.5    C. 5.25    D. 0.525    E. 0.0525    F. None of A-E
6. As a percent, 5.35 is...
- A. 0.535%    B. 5.35%    C. 53.5%    D. 535%    E. None of A-D
7. As a decimal, 1.775% is...
- A. 0.01775    B. 0.1775    C. 1.775    D. 17.75    E. None of A-D
8. 1.5% = ...
- A. 150    B. 15    C. 1.5    D. 0.15    E. 0.015
9. Put these in order, smallest to largest:  $\frac{15}{19}$      $\frac{300}{400}$      $\frac{11}{16}$      $\frac{3000}{4001}$      $\frac{3}{8}$
10. Put these in order, smallest to largest: 0.03    0.0295    0.1    0.13999
11. Put these in order, smallest to largest:  $\frac{203}{300}$      $\frac{200}{303}$      $\frac{6}{9}$      $\frac{9}{12}$
12. Put these in order, smallest to largest: 8.5%    1.7     $\frac{15}{11}$      $\frac{14}{8}$     110%
13. Put these in increasing order without any hand calculation:
- $\frac{11}{40}$     0.0239    0.81     $\frac{211}{392}$      $\frac{200}{31}$
14. As a fraction, 1.4 =
- A.  $\frac{1}{4}$     B.  $\frac{7}{5}$     C.  $\frac{14}{100}$     D.  $\frac{41}{10}$     E. None of A-D
15. An example of a number between  $\frac{2}{5}$  and  $\frac{3}{5}$  is...
- A.  $\frac{19}{40}$     B. 0.4    C. 27%    D.  $1\frac{1}{3}$     E. None of A-D
16. For positive a and b, the fraction  $\frac{a}{b}$  is less than 1 whenever...
- A.  $a < 1$     B.  $b < 1$     C.  $a < b$     D.  $b < a$     E. None of A-D

17. Which of the following is the correct form for 932.12, in scientific notation?

- A. 932.12    B.  $93212 \times 10^2$     C.  $9321.2 \times 10^1$     D.  $9.3212 \times 10^2$     E.  $9.3 \times 10^2$

18. 0.00056, in scientific notation, would be written...

- A. 5.6    B.  $5.6 \times 10^4$     C.  $5.6 \times 10^{-4}$     D.  $56 \times 10^{-5}$     E. None of A-D

19. Make a drawing that shows  $2\frac{4}{5}$ , if the shape below is 1.



20. What number describes the shaded part of this region?



- A.  $\frac{3}{2}$     B.  $\frac{2}{3}$     C.  $\frac{4}{2}$     D. 60%    E. None of A-D

21. 7 tenths plus 4 tenths equal ...

- A. 0.11    B. 0.28    C. 1.1    D. 2.8    E. None of A-D

22. 75% of 36,000 is...

- A. 2,700,000    B. 2,520,00    C. 27,000    D. 2700    E. 2520

23. How many \$10 bills could one get for \$10 million?

- A. 1,000,000    B. 100,000    C. 10,000    D. 1000    E. None of A-D

24. How many \$100 bills could one get for a billion dollars?

- A. 100,000,000    B. 10,000,000    C. 1,000,000    D. 100,000    E. None of A-D

25.  $1\frac{7}{12} + 2\frac{5}{11} + 3\frac{5}{12} + \frac{7}{13}$  is about...

- A.  $8\frac{1}{2}$     B. 8    C.  $7\frac{12}{24}$     D.  $6\frac{24}{48}$     E. None of A-D

26. 20% of 150 is  $\frac{1}{3}$  of ...

- A. 10    B. 90    C. 120    D. 250    E. 900

27.  $42,189 \div 511,264$  is about how many percent?

- A. 8%    B. 12.5%    C. 80%    D. 125%    E. None of A-D

28. Which of A-E would best locate the point for  $0.89 \cdot n$  on a number line ( $n$  is positive)?

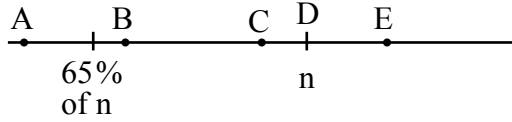

29. Which of A-E would best locate the point for  $n \div 0.89$  on a number line ( $n$  positive)?

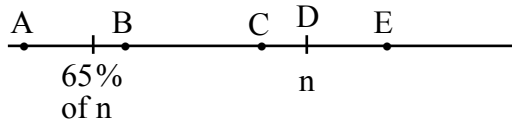

30. A person can reasonably calculate the exact answer to  $1563 - 198$  mentally by...

- A. counting on his/her fingers    B. calculating  $1565 - 200$   
 C. calculating  $1565 - 200 - 2$     D. calculating  $1600 - 200$   
 E. This calculation is impossible to do mentally.

31. A person who is calculating the exact answer to  $18 \times 15$  mentally starts by calculating  $2 \times 15$ . The person would finish the mental calculation by calculating...

- A.  $9 \times 30$     B.  $27 \times 10$     C.  $36 \times 7.5$     D.  $60 \times 4.5$     E. None of A-D works.

32.  $53_{\text{six}}$  names the same number as which of these base ten numerals?

- A. 186    B. 183    C. 125    D. 85    E. 33

33. In base ten,  $111_{\text{five}}$  would be written...

- A. 421    B. 155    C. 31    D. 21    E. None of A-D

34. The base  $b$  numeral  $321_b$  means...

- A.  $3 \cdot b^2 + 2 \cdot b^1 + 1$     B.  $3 \cdot b^3 + 2 \cdot b^2 + 1 \cdot b^1$     C.  $6b$     D.  $3 \cdot b + 2 \cdot b + 1$

35. In base five,  $32_{\text{ten}}$  would be written...

- A.  $152_{\text{five}}$     B.  $112_{\text{five}}$     C.  $62_{\text{five}}$     D.  $17_{\text{five}}$     E. None of A-D

36. The base two numeral  $100_{\text{two}}$  equals the base ten numeral...

- A. 1100100    B. 1011100    C. 8    D. 4    E. None of A-D

37. In base ten,  $32_{\text{four}}$  would be written...

- A. 400    B. 200    C. 122    D. 14    E. 8

38. The base four numeral  $11.1_{\text{four}}$  could be written in base ten as...

- A.  $33\frac{1}{4}$     B.  $33\frac{1}{10}$     C.  $11\frac{1}{4}$     D.  $5\frac{1}{4}$     E. None of A-D

39. The base ten decimal 18.5 could be written in base six as ...

- A.  $10.5_{\text{six}}$     B.  $20.3_{\text{six}}$     C.  $30.3_{\text{six}}$     D.  $128.5_{\text{six}}$     E. None of A-D

40. The base ten fraction  $\frac{1}{4}$  equals which base eight numeral?

- A.  $0.2_{\text{eight}}$     B.  $0.14_{\text{eight}}$     C.  $0.02_{\text{eight}}$     D.  $1.4_{\text{eight}}$     E. None of A-D

41. If  $31_b = 28_{\text{ten}}$ , then  $b = \dots$

- A. 4    B. 5    C. 7    D. 9    E. This is impossible for any whole number  $b$ .

42-44. Finish the following story to make story problems that could be solved by the indicated calculation.

"The farmer has a  $3\frac{1}{2}$  acre orchard of orange trees...."

42.  $\frac{2}{3} \times 3\frac{1}{2}$

43.  $3\frac{1}{2} \div 5$

44.  $3\frac{1}{2} \div 0.8$

45. What calculation would solve this story problem?

"Cheese was \$2.55 a pound. A woman bought a 0.85 pound package of the cheese. How much did she pay?"

- A.  $2.55 + 0.85$     B.  $2.55 - 0.85$     C.  $0.85 \times 2.55$     D.  $2.55 \div 0.85$

46. What calculation would solve this story problem?

"George had  $\frac{4}{5}$  of a pie. He ate  $\frac{2}{3}$  of what he had. What part of a pie did he eat?"

- A.  $\frac{4}{5} + \frac{2}{3}$     B.  $\frac{4}{5} - \frac{2}{3}$     C.  $\frac{2}{3} \times \frac{4}{5}$     D.  $\frac{4}{5} \div \frac{2}{3}$     E. None of A-D

47. What calculation would solve this story problem?

"She paid \$4.80 for  $\frac{3}{4}$  pound of candy. How much does the candy cost per pound?"

- A.  $(4.80 \div 4) \times 4$     B.  $4.80 \times \frac{3}{4}$     C.  $4.80 \div \frac{3}{4}$     D.  $4.80 + 0.75$     E. None of A-D

48. A store sells 48 pecan pies for every 15 banana pies it sells. At this rate, if the store sells 60 banana pies, it will sell how many pecan pies?

- A. 12    B. 60    C. 120    D. 192    E. None of A-D

49. The pollster noticed that for every 40 men who were in favor of X, there were 28 women who were in favor of X. According to these figures, if 280 men were in favor of X, how many women were in favor of X?

- A. 400    B. 196    C. 168    D. 40    E. None of A-D

50. A machine can make 700 bolts in 40 minutes. At that rate, how many bolts can the machine make in one hour?

- A. 900    B. 1050    C. 2800    D. 28,000    E. None of A-D

51. If the hearts shown represent  $\frac{2}{5}$  of all the chocolate hearts you gave away on Valentine's Day, how many chocolate hearts did you give away in all?



- A. 8    B. 28    C. 30    D. 50    E. None of A-D

52. If the apples shown are  $\frac{3}{4}$  of the apples used for pies, how many apples were used for pies in all?

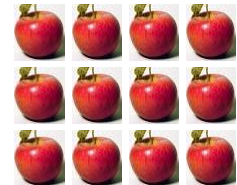

- A. 3    B. 9    C. 16    D. 25    E. None of A-D

53. If  $\frac{3}{4}$  of the apples shown above were red apples, how many of the apples were red?

- A. 3    B. 9    C. 16    D. 25    E. None of A-D

54. Tuna costs 70¢ a can at Store X and 80¢ a can at Store Y. How much will 8 cans of tuna cost, if  $\frac{1}{4}$  of the cans are bought at Store X and the rest at Store Y?
- A. \$1.40    B. \$4.80    C. \$5.60    D. \$6.20    E. None of A-D
55. One day Joe's old car used  $\frac{5}{8}$  quarts of oil. The next day it used only  $\frac{2}{3}$  as much oil. How many quarts of oil did the car use on the second day?
- A.  $\frac{5}{8} + \frac{2}{3}$     B.  $\frac{2}{3} \times \frac{5}{8}$     C.  $\frac{5}{8} \div \frac{2}{3}$     D.  $\frac{2}{3} \div \frac{5}{8}$     E. None of A-D
56. On day 3 the car used  $1\frac{1}{4}$  quarts of oil! But on day 4 it used only 60% as much as it did on day 3. How many quarts of oil did the car use on day 4?
- A.  $1\frac{1}{4} + 0.60$     B.  $1\frac{1}{4} - 0.60$     C.  $\frac{3}{5} \times 1\frac{1}{4}$     D.  $1\frac{1}{4} \div \frac{60}{100}$     E. None of A-D
57. How many  $\frac{2}{3}$  pound portions can be obtained from 30 pounds?
- A. 20    B. 45    C. 60    D. 90    E. None of A-D
58. Karen and Sara go bike riding. Karen biked for  $3\frac{1}{3}$  hours, which was  $\frac{2}{3}$  as many hours as Sara biked. How many hours did Sara bike?
- A.  $2\frac{2}{9}$     B.  $2\frac{2}{3}$     C. 4    D. 5    E. None of A-D
59. After a family had gone 140 miles, the kids asked, "Are we almost there?" The driver said, "We've only gone  $\frac{2}{7}$  of the way." How far did the family still have to go?
- A. 40 miles    B. 80 miles    C. 350 miles    D. 490 miles    E. None of A-D
60. A husband says to his wife, "Wife, you drove 80% as far as I did on the trip." If the husband drove 200 miles farther than the wife did, how long was the whole trip?
- A. 250 miles    B. 360 miles    C. 1800 miles    D. 2500 miles    E. None of A-D

61-62. After splitting a large amount of candy with older sibling Al, children Bea and Cid are upset.

Bea says, "I only got  $\frac{2}{3}$  as much as you did, Al!"

Cid says, "Me too!"

61. What part of all the candy did Al get?

- A.  $\frac{3}{10}$     B.  $\frac{3}{7}$     C.  $\frac{4}{9}$     D.  $\frac{4}{3}$     E. None of A-D

62. If there were 210 pieces of candy originally, how many pieces did Bea get?

- A. 42    B. 60    C. 63    D. 70    E. 140

63. Monday:    juice of 6 oranges, plus 8 cups of water  
 Tuesday:    juice of 9 oranges, plus 12 cups of water  
 Wednesday:    juice of 4 oranges, plus 5 cups of water  
 Thursday:    juice of 2 oranges, plus 3 cups of water

Which day did the juice-water mixture taste most orange-y?

- A. Monday    B. Tuesday    C. Wednesday    D. Thursday    E. None of A-D

64. It takes the farmer's chickens  $3\frac{1}{3}$  days to lay 6 dozen eggs. How many eggs can the farmer expect to get in 10 days?

- A. 18    B. 200    C. 216    D. 240    E. None of A-D

65. If the city's budget of \$2.0 million this year is 125% of last year's budget, what was last year's budget?

- A. \$1.6 million    B. \$2.5 million    C. \$62.5 million    D. \$250 million

66. In 1996 the city's budget was \$100 million. The 1997 budget figure was 20% higher than the 1996 figure, and the 1998 budget figure was 5% higher than the 1997 figure. What was the 1998 budget figure, in millions of dollars?

- A. \$75 million    B. \$80 million    C. \$125 million    D. \$126 million

67. Miguel runs 200m in 40 seconds; Paul runs 150m in  $\frac{1}{2}$  minute. Who runs faster?

- A. Miguel    B. Paul    C. They run at the same speed.

## Review Items for Part 2 of the Assessment (Geometry and Measurement)

1. What is the sum of the number of edges and the number of vertices of an octagonal pyramid?

A. 25    B. 22    C. 9    D. 23    E. None of A-D

2. Which of these is safe to say about every square pyramid?

X. Every lateral edge has the same length.  
Y. All of the angles on each face are equal.  
Z. Every base edge has the same length.

A. X only    B. Y only    C. Z only    D. X and Z only    E. None of A-D

3. Consider the statement: The diagonals of a parallelogram are equal.

Is this statement:

A. always true?    B. sometimes true?    C. never true?

4. What is the best name for the shape to the right?

A. polyhedron  
B. eight-gon  
C. hexagonal prism  
D. octahedron  
E. None of A-D

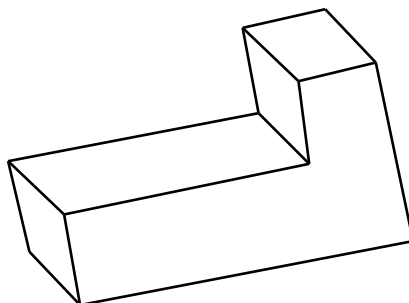

5. If a polygon is equiangular, then it must be:

A. equilateral    B. regular    C. a triangle    D. both a and b.    E. None of A-D

6. I am a polyhedron with a total of 9 faces. My 8 lateral faces are isosceles triangles.  
My best name is:

A. 9-gon    B. octagonal pyramid    C. 9-gonal pyramid    D. octagonal prism  
E. regular octagonal pyramid    F. triangular pyramid

7. A square is a rhombus:

- A. always    B. sometimes    C. never

8. How many faces cannot be seen in this drawing of a pentagonal pyramid?

- A. 0  
B. 1  
C. 2  
D. 3  
E. 4

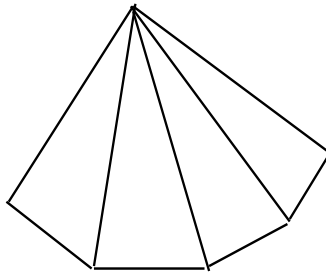

9. The sizes of three interior angles of a quadrilateral are  $65^\circ$ ,  $35^\circ$ , and  $60^\circ$ . What is the size of the fourth angle of the quadrilateral?

- A.  $20^\circ$     B.  $100^\circ$     C.  $160^\circ$     D.  $200^\circ$     E. This quadrilateral is impossible.

10. An isosceles triangle has two angles, one with  $40^\circ$  and the other with  $100^\circ$ . How large is the third angle?

- A.  $40^\circ$     B.  $60^\circ$     C.  $100^\circ$     D.  $140^\circ$     E. Not enough info

11. In a photograph of two buildings, Building A is 5 cm tall and Building B is 7 cm tall. In an enlargement of the photograph, Building A is 8 cm tall. How tall is Building B in the enlargement?

- A. 10 cm    B.  $11\frac{1}{5}$  cm    C.  $4\frac{3}{8}$  cm    D. Not enough info

12-13. Use the triangles below to answer the following questions:

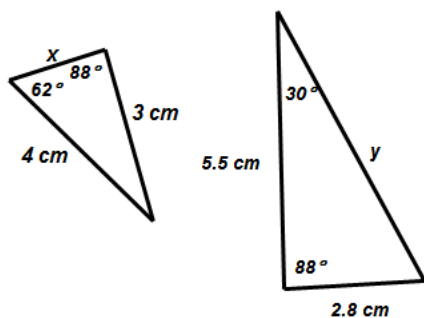

12. What is the length of  $x$ , to the nearest tenth cm?  
 A. 1.5 cm  
 B. 5.1 cm  
 C. 0.3 cm  
 D. 1.3 cm  
 E. Need more info
13. What is the length of  $y$ , to the nearest tenth cm?  
 A. 6.5 cm  
 B. 4.2 cm  
 C. 2.2 cm  
 D. 7.3 cm  
 E. Need more info

14. Refer to the similar figures below. What is the length of  $x$ , to the nearest tenth cm?

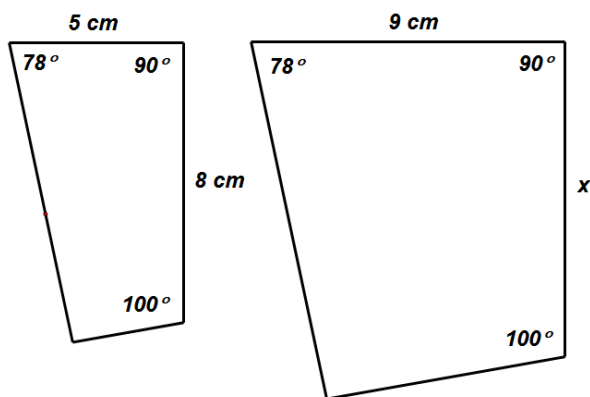

- A. 3.9 cm  
 B. 12.6 cm  
 C. 11.0 cm  
 D. 12.0 cm  
 E. 14.4 cm

15. How many faces, edges, and vertices does a 100-gonal prism have?

- i. The number of faces is...  
 A. 101    B. 102    C. 300    D. 200    E. None of A-D
- ii. The number of edges is...  
 A. 101    B. 102    C. 300    D. 200    E. None of A-D
- iii. The number of vertices is...  
 A. 101    B. 102    C. 300    D. 200    E. None of A-D

16. Two pentagons have the following lengths of sides:

Pentagon A: 7 cm, 7 cm, 7 cm, 7 cm, 10 cm

Pentagon B: 4 cm, 4 cm, 4 cm, 4 cm, 7 cm

Are Pentagons A and B similar?

A. Yes, since the differences between the corresponding sides are the same, 3 cm.

B. Yes, since they are both regular pentagons.

C. Yes, since the ratios between the corresponding sides are the same.

D. No, since some ratios between corresponding lengths are different,  $\frac{7}{4}$  and  $\frac{10}{7}$ .

17. For each statement, circle the most appropriate measurement:

i. The area of this page is about... 6 cm<sup>2</sup>    6 dm<sup>2</sup>    6 mm<sup>2</sup>

ii. The area of the floor in a math classroom is about... 80 cm<sup>2</sup>    80 dm<sup>2</sup>    80 m<sup>2</sup>

iii. The volume of a trash can in a classroom is about... 45 cm<sup>3</sup>    45 dm<sup>3</sup>    45 m<sup>3</sup>

iv. The amount of water in an aquarium could be... 50 dm    50 dm<sup>2</sup>    50 dm<sup>3</sup>

18. Find the approximate volume of the cone with the following dimensions:

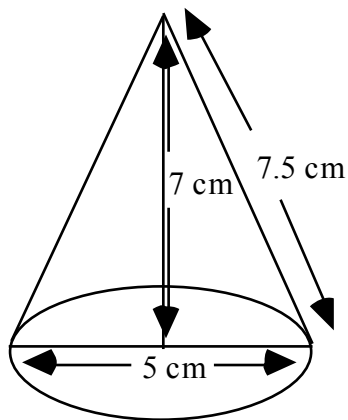

A. 137.4 cubic cm

B. 45.8 cubic cm

C. 147.3 cubic cm

D. 69.1 cubic cm

E. 183.3 cubic cm

19. Find the area of the figure below (angles that look like right angles are right angles).

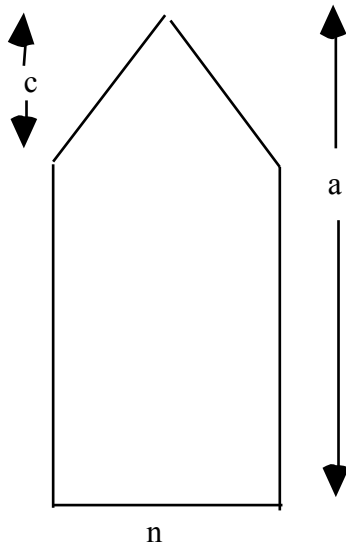

- A.  $na + \frac{1}{2}(nc)$  square units
- B.  $n(c - a) + \frac{1}{2}(nc)$  square units
- C.  $n(c + a) + \frac{1}{2}(nc)$  square units
- D.  $n(a - c) + \frac{1}{2}(nc)$  square units
- E. None of A-D

20. Triangle ABC is similar to triangle DEC, with AB parallel to DE. If you know that AC = 6 cm, AB = 4 cm, DC = 10 cm, and CE = 13 cm, find the lengths of the other segments and the measures of the angles not given.

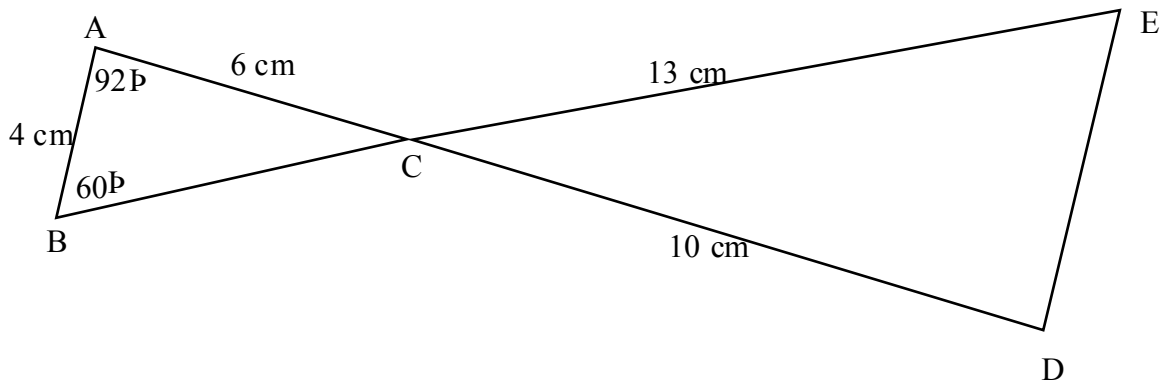

Measure of  $\angle BCA =$  \_\_\_\_\_      Measure of  $\angle ECD =$  \_\_\_\_\_

Measure of  $\angle D =$  \_\_\_\_\_      Measure of  $\angle E =$  \_\_\_\_\_

Length of BC = \_\_\_\_\_      Length of DE = \_\_\_\_\_

21. Ollie measures the area of his kitchen floor and finds that it is 2400 square decimeters. How many square meters is it?

- A.  $2.4 \text{ m}^2$     B.  $24 \text{ m}^2$     C.  $240 \text{ m}^2$     D. Not enough information

22. The diagonals of every parallelogram....

- A. bisect the angles of the parallelogram    B. are parallel to each other  
 C. are perpendicular to each other    D. are equal in length    E. None of A-D

23. A rectangular pyramid has how many edges, faces, and vertices?

- i. The number of edges is:  
 A. 8    B. 12    C. 5    D. 6
- ii. The number of faces is:  
 A. 8    B. 12    C. 5    D. 6
- iii. The number of vertices is:  
 A. 8    B. 12    C. 5    D. 6

24. Find the length of diagonal AC in the following right rectangular prism.

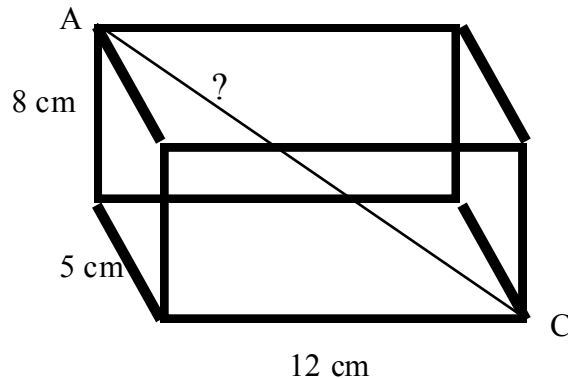

- A. 15.3 cm    B. 13 cm    C. 9.4 cm    D. 20 cm    E. 48 cm

25. Which of these is true for every square prism?

- X. Every angle in a face is a right angle.  
 Y. Every lateral edge has the same length.  
 Z. All the edges have the same length.
- A. X and Y only    B. X and Z only    C. Y and Z only    D. X, Y, and Z  
 E. None of A-D

26. Which of these is true for every rhombus?
- I. The diagonals of a rhombus must be equal.
  - II. The sides of a rhombus must be equal.
- A. I only    B. II only    C. I and II    D. Neither I nor II
27. If IJKLMN is a regular polygon, then...
- A. all the diagonals are equal in length.
  - B. IJKLMN has 7 sides.
  - C. angle JKL has twice as many degrees as angle LMN.
  - D. IJKLMN has exactly 7 symmetries.
  - E. none of A-D
28. What is the sum of the number of faces and the number of vertices of an n-gonal prism?
- A.  $2n$     B.  $n+2$     C.  $3n$     D.  $3n+2$     E. None of A-D
29. Which of these is true about every right rectangular prism (rectangular solid)?
- X. All the edges have the same length.
  - Y. All the angles on each face have the same size.
  - Z. Each edge is perpendicular to the edges it meets.
- A. X only    B. Y only    C. Z only    D. Y and Z only    E. None of A-D
30. Of the following, which is the best technical name for a filing cabinet?
- A. box    B. square box    C. prism    D. right prism    E. square prism
31. How are the diagonals of every rectangle related?
- X. The diagonals are the same length.
  - Y. The diagonals are perpendicular.
  - Z. The diagonals bisect the angles of the rectangle.
- A. X only    B. Y only    C. Z only    D. X and Z only    E. None of A-D
32. T F Every square is a special quadrilateral.  
T F Every square is a quadrilateral.  
T F Every square is a rectangle.  
T F Every rectangle is a parallelogram.

32. (continued)

- T F Every rhombus is a parallelogram.
- T F Every rectangle is a special square.
- T F Every trapezoid is a special parallelogram.
- T F Any fact that is true for every parallelogram is also true for every square.
- T F Any fact that is true for every rectangle is also true for every quadrilateral.

33. A plan calls for running a telephone line from P to Q to R. The line costs \$7/meter. If it is feasible to run the line directly from P to R, how much money would one save?

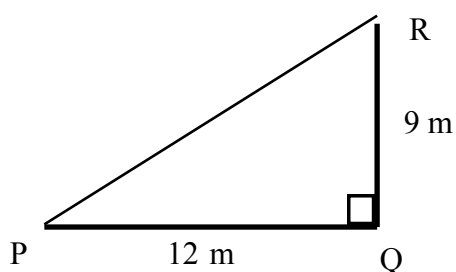

- A. \$ 42
- B. \$105
- C. \$147
- D. \$ 6
- E. \$378

34. What is the area of a rectangle with perimeter 20 meters and base 6 meters?

- A.  $120 \text{ m}^2$
- B.  $60 \text{ m}^2$
- C.  $160 \text{ m}^2$
- D.  $24 \text{ m}^2$
- E.  $84 \text{ m}^2$

35. What is the length in centimeters of the base of a rectangle with a diagonal of length  $m$  cm and a height of length  $n$  cm?

- A.  $\sqrt{m^2 + n^2}$
- B.  $\sqrt{m^2 - n^2}$
- C.  $m - n$
- D.  $\frac{mn}{2}$
- E.  $\frac{m - n}{2}$

36. You would like to buy wheels for your child's go-cart so that the wheels will roll 1 meter in full revolution. About what should the diameter of each wheel be?

- A. 0.32 m
- B. 0.56 m
- C. 1.13 m
- D. 1 m
- E. 3.14 m

37. What is the area of the trapezoid shown below?

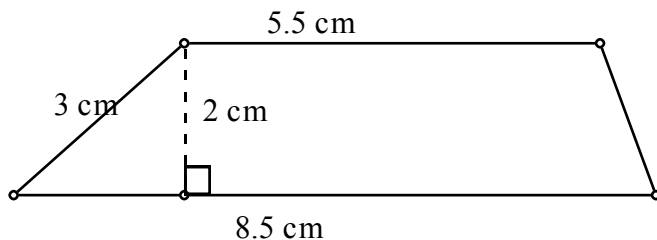

- A.  $28 \text{ cm}^2$
- B.  $280.5 \text{ cm}^2$
- C.  $21 \text{ cm}^2$
- D.  $14 \text{ cm}^2$
- E.  $19 \text{ cm}^2$

38. What is the area of a larger rectangle similar to the one shown, with lengths 4 times as long as they are here?

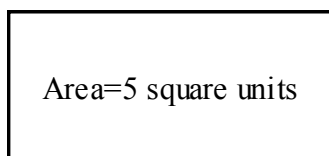

- A. 5 square units  
 B. 9 square units  
 C. 20 square units  
 D. 80 square units  
 E. 625 square units
39. Cube A has edges that are 3 times as long as the edges of Cube B. The volume of Cube A is 108 cubic cm. What is the volume of Cube B?
- A.  $36 \text{ cm}^3$     B.  $324 \text{ cm}^3$     C.  $12 \text{ cm}^3$     D.  $4 \text{ cm}^3$     E. None of A-D
40. The length of a baby's head (top of head to chin) is about one-fourth of the entire length of a baby. If the baby is 56 cm long, how long is the baby's head?
- A. 14 cm    B. 70 cm    C. 224 cm    D. 18 cm    E. Not enough info
41. Triangle A and triangle B are similar. The area of triangle A is 560 square cm. The area of triangle B is 35 square cm. How long would a segment in triangle A be, if the corresponding segment in triangle B is 4 cm?
- A. 64 cm    B. 16 cm    C. 4 cm    D. 1 cm    E. Not enough info
42. Find the measure of angle A of the triangle.

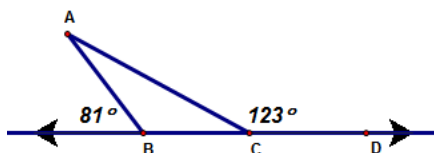

- A.  $156^\circ$   
 B.  $24^\circ$   
 C.  $57^\circ$   
 D.  $20^\circ$   
 E. Not enough info
43. What is the measure of one interior angle of a regular 18-gon?
- A.  $10^\circ$     B.  $2880^\circ$     C.  $180^\circ$     D.  $160^\circ$     E. not enough info
44. How many decimeters (to the nearest decimeter) are in 4.928 meters?
- A. 1    B. 5    C. 49    D. 9    E. 493
45. Susan is 166 cm tall and in the afternoon she casts a shadow about 55 cm long. Her sister, who is standing next to her, casts a shadow about 35 cm long. About how tall is Susan's sister?
- A. 146 cm    B. 105 cm    C. 95 cm    D. 90 cm    E. 12 cm

46. What is the area of the circle below?



length of diameter =  
3 inches

- A.  $2.25\pi$  square inches
- B.  $9\pi$  square inches
- C.  $6\pi$  square inches
- D.  $3\pi$  square inches
- E.  $1.5\pi$  square inches

47. What is the best name for a four-sided polygon with equal sides?

- A. square
- B. parallelogram
- C. rectangle
- D. rhombus
- E. kite

48. What is the volume of the box below?

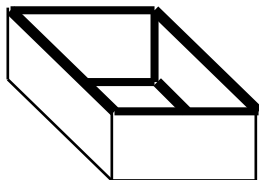

Height of box = 2.5 inches  
Area of bottom of box = 35 sq. inches  
Length of diagonal of bottom = 8.5 inches

- A. 87.5 cubic inches
- B. 743.75 cubic inches
- C. 297.5 cubic inches
- D. 46 cubic inches
- E. 37.5 cubic inches

49. What is the area of the figure below (use the natural unit)?

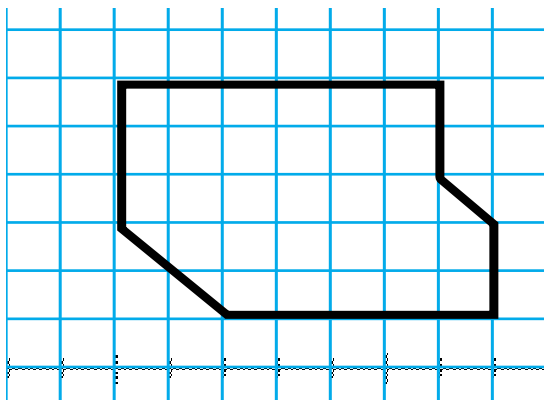

- A. 35 square units
- B. 30 square units
- C.  $30\frac{1}{2}$  square units
- D. 32 square units
- E. None of A-D

50. If the volume of a right circular cylinder with radius 5 cm is about 550 cubic cm, about what is the height of the cylinder?

- A. 110 cm    B. 35 cm    C. 22 cm    D. 7 cm    E. 3 cm

51. A triangle is similar to a larger triangle that has lengths 3 times as long as the corresponding lengths in the smaller triangle. How large is the angle in the smaller triangle that corresponds to a  $30^\circ$  angle in the larger triangle?

- A.  $10^\circ$     B.  $30^\circ$     C.  $90^\circ$     D.  $270^\circ$     E. None of A-D

52-53. Consider the shape to the right, made of centimeter cubes glued together face-to-face.

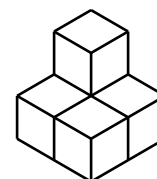

52. What is the volume of the shape, in cubic centimeters?

- A. 11    B. 10    C. 8    D. 6    E. 5

53. A larger shape, similar to the one above, is also made of cubes. The larger shape is twice as tall, twice as wide, twice and deep, and in general twice as long in every corresponding length dimension. What is the volume of the larger shape, in cubic centimeters?

- A. 40    B. 20    C. 16    D. 0    E. None of A-D

54. What is the area of the hexagonal region to the right, in square centimeters? Assume that lines that look parallel are parallel, and that angles that look like right angles are right angles.

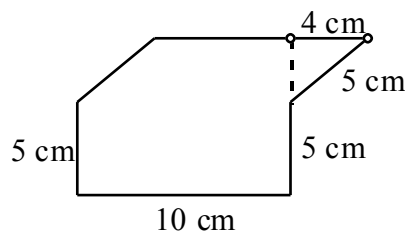

- A. 100    B. 80    C. 65    D. 40    E. 29

55. A male basketball player is most likely to be...

- A. 2.2 dm tall    B. 2.2 m tall    C. 2.2 hm tall    D. 2.2 km tall    E. 2.2 cm tall

56. The perimeter of a square is 20 cm. What is its area, in  $\text{cm}^2$ ?

- A. 400    B. 80    C. 25    D. 20    E. None of A-D

57. What is the area of the triangle to the right, in  $\text{cm}^2$ ? Given measurements are in cm.

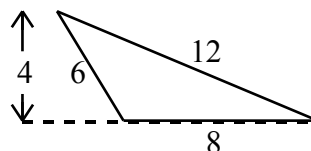

- A. 32    B. 30    C. 24    D. 16    E. None of A-D

58. The triangular region in number 57 is the base of a pyramid 18 cm high. What is the volume of this pyramid, in  $\text{cm}^3$ ?

- A. 864    B. 288    C. 144    D. 96    E. Need more info

59-60. Pinocchio's nose grew to 4 times its normal length.

59. If the rest of Pinocchio's body grew in the same way, what would be his new volume?

- A. 4 times his original volume    B. 8 times his original volume  
 C. 16 times his original volume    D. 64 times his original volume  
 E. None of A-D

60. If all of Pinocchio's body grew in the same way, what would his new surface area be?

- A. 4 times his original surface area    B. 8 times his original surface area  
 C. 16 times his original surface area    D. 64 times his original surface area  
 E. None of A-D

61. Which of the following is(are) IMPOSSIBLE for  $x$ ,  $y$ , and  $z$  in the sketch to the right? (The drawing is not to scale.)

- i.  $x = 100, y = 110, z = 150$   
 ii.  $x = 80, y = 130, z = 150$

- A. Only i is impossible.  
 B. Only ii is impossible.  
 C. Both i and ii are impossible.  
 D. Each of i and ii is possible.

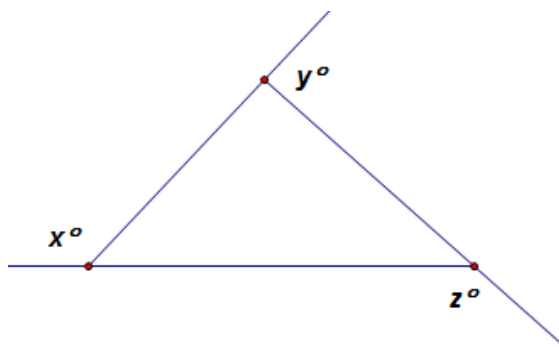

**Answers to the Review Questions for Numbers and Operations**

1. C (from  $\frac{3}{4} \times 160$ )
2. A
3. B
4. D ( $\frac{1}{3} \times 630$  is a better estimate than  $\frac{1}{3} \times 600$ )
5. F ("Percent" means "hundredths," so  $0.525\% = 0.00525$ .)
6. D
7. A
8. E
9.  $\frac{3}{8} \frac{11}{16} (< \frac{12}{16} = \frac{3}{4}) \frac{3000}{4001} (< \frac{3}{4}) \frac{300}{400} (= \frac{3}{4}) \frac{15}{19} (> \frac{15}{20} = \frac{3}{4})$
10. 0.0295    0.03    0.1    0.13999
11.  $\frac{200}{303}$      $\frac{6}{9}$      $\frac{203}{300}$      $\frac{9}{12}$
12. 8.5%    110%     $\frac{15}{11}$     1.7     $\frac{14}{8}$
13. 0.0239     $\frac{11}{40}$      $\frac{211}{392} (> \frac{1}{2})$     0.81     $\frac{200}{31}$
14. B
15. A
16. C
17. D
18. C

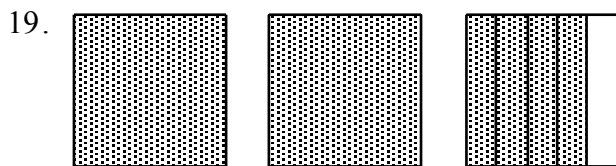

20. B
21. C
22. C
23. A
24. B
25. B
26. B

27. A ( $\frac{42}{511} \approx \frac{40}{500} = \frac{8}{100}$ )

28. C

29. E

30. B

31. A

32. E

33. C

34. A

35. B

36. D

37. D

38. D

39. C

40. A

41. D

42. One example: "... Two-thirds of the orchard had Valencia oranges. How many acres of Valencia oranges did the farmer have?" Your story should involve  $\frac{2}{3}$  of the  $3\frac{1}{2}$  acres. Other ideas might revolve around fertilizing or picking part of the orchard,...

43. One example: "...The farmer decided to pick all the oranges in one 5-day week. How many acres per day must the farmer average?"

44. One example: "...The farmer could pick the oranges on 0.8 acres a day. How many days would it take her to pick all the oranges in the orchard?"

45. C (This involves the part-of-an-amount kind of multiplication.)

46. C (This involves the part-of-an-amount kind of multiplication.)

47. C

48. D

49. B

50. B

51. D (The display is the  $\frac{2}{5}$ , so half of it would be  $\frac{1}{5}$  of the hearts given away.)

52. C (As in 51, the display is  $\frac{3}{4}$ , so  $\frac{1}{3}$  of it would be  $\frac{1}{4}$  of the total number of apples.)

53. B (Notice the difference between 53 and 52.)

54. D

55. B (Again, this problem involves the part-of-an-amount kind of multiplication.)

- 56. C
- 57. B ("How many  $\frac{2}{3}$  s are in 30" can be answered by division,  $30 \div \frac{2}{3}$ .)
- 58. D (Making a drawing is almost essential on such problems.)
- 59. C (Again, making a drawing is helpful.)
- 60. C (Making a drawing is almost essential on this problem.)
- 61. B (Making a drawing is almost essential on this problem.)
- 62. B
- 63. C
- 64. C
- 65. A
- 66. D
- 67. C

### **Answers to the Review Questions for Geometry and Measurement**

- 1. A (You should know all of the common prefixes: tri-, quadri-, penta-, hexa-, octa-.)
- 2. C (You should be clear on the "p"-words--pyramid, prism, polyhedron.)
- 3. B
- 4. C
- 5. E
- 6. E
- 7. A
- 8. C
- 9. D
- 10. A
- 11. B
- 12. A (Note: number sense may speed up the decision-making in a multiple-choice item.)
- 13. D
- 14. E
- 15. i. B    ii. C    iii. D (Visualize where the faces, vertices, and edges are.)
- 16. D
- 17. i.  $6 \text{ dm}^2$     ii.  $80 \text{ m}^2$     iii.  $45 \text{ dm}^3$     iv.  $50 \text{ dm}^3$
- 18. B
- 19. D

20.  $m\angle BCA = 28^\circ$ ,  $m\angle ECD = 28^\circ$ ,  $m\angle D = 92^\circ$ ,  $m\angle E = 60^\circ$ ,  $BC = 7.8$  cm,  $DE = 6\frac{2}{3}$  cm

(Keeping straight which parts correspond is important; labeling may be helpful.)

21. B

22. E

23. i. A    ii. C    iii. C

24. A (The Pythagorean theorem is a very useful tool whenever right angles are at hand.)

25. E

26. B

27. E ("Make a drawing" is a good problem-solving strategy.)

28. D

29. D

30. D

31. A

32. T, T, T, T, T, F, F, T, F

33. A

34. D ("Make a drawing" is a good problem-solving strategy.)

35. B

36. A

37. D

38. D (How the areas of similar shapes are related is not intuitive.)

39. D (How the volumes of similar shapes are related is not intuitive.)

40. A

41. B (How the areas of similar shapes are related is not intuitive.)

42. B

43. D

44. C

45. B

46. A

47. D

48. A ( $V = Bh$  for prisms and cylinders, and  $V = \frac{1}{3} Bh$  for pyramids and cones.)

49. C

50. D

51. B

52. E

53. A

54. B

55. B

56. C

57. D

58. D

59. D

60. C

61. D